

KITCHEN EXHAUST FANS



KITCHEN EXHAUST FANS

DAYNFLOW Kitchen exhaust hood aspiratores are used for exhausting smoke and gases which occurred at the cooking place. smoke and gases first passes though the metal grease filter and then exhaust the air outdoor with high efficiency plug fan. motor is installed out of air stream to prevent any damage due to high air flow temprature.

Features and Benefits

- *TSEK certification.*
- *The design, providing fast and easy installation and maintenance.*
- *High efficiency direct drive plug fan.*
- *All standard models are available in stock.*
- *Meral oill filter.*
- *Fan speed control.*
- *Differential pressure switch for filter.*
- *Optional parts: Active carbon filter.*

DMD VERTICAL DUCT TYPE KITCHEN EXHAUST FANS

DYNFLOW DMD Vertical Duct Type Kitchen Exhaust Fans are used for kitchen smoke and gases exhausting which are generated at cooking area. DMD Vertical exhaust Fans are applicable to be equipped with optional metallic filter. Motor is installed out of airstream to prevent any damage due to the high airflow temperature.

Features and Benefit

- Special design with fast and easy installation and maintenance.
- Backward curved high efficiency direct driven plug fan.
- IP 55 protection class motor with F-class insulation.
- 400 Volt – 3 Phase – 50Hz.
- Motor out-of-stream arrangement.
- Options:
 - Metallic Filter with drain connection.
 - Carbon active filter.
 - Speed Controller.
 - Differential Pressure switch.

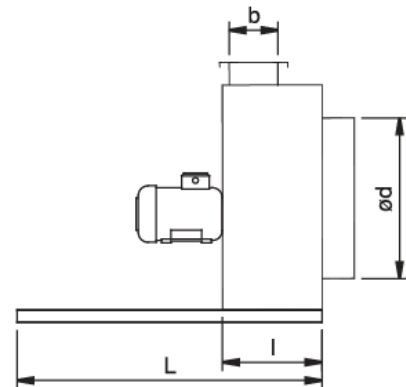
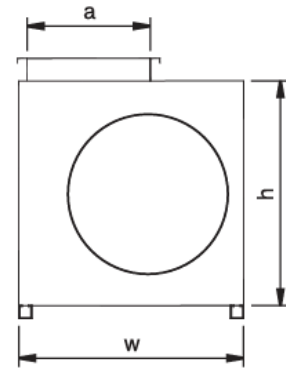
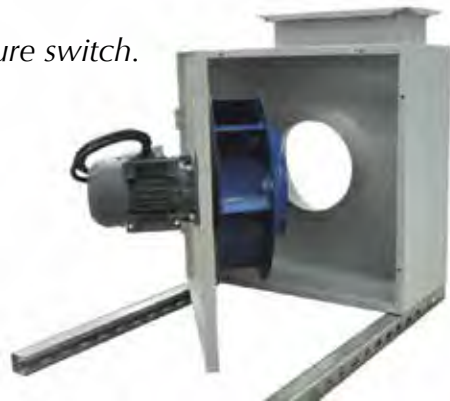

DMD Specifications

Fan Type			DMD 35	DMD 40	DMD 45	DMD 50	DMD 56
Electrical Data	Connections		400 V / 50 Hz / 3 PH				
	Power	[kW]	0.37	0.75	1.1	1.5	3
	Current	[A]	1.2	2.2	2.7	3.4	6.7
	RPM	[d/d]	1500	1500	1500	1500	1500
Dimensions	W+10	[mm]	550	650	700	800	900
	H+10	[mm]	550	650	700	800	900
	L+10	[mm]	530	570	600	660	777
	l	[mm]	281	298	310	343	400
	AXB	[mm]	300X140	350X140	380X150	440X170	490X200
	ød	[mm]	355	400	450	500	560
	Weight	[kg]	32	45	70	85	105

Model	DUCT TYPE KITCHEN EXHAUST FAN					Duct type Kitchen Exhaust fan + Filter				
	DMD 35	DMD 40	DMD 45	DMD 50	DMD 56	DMD-F 35	DMD-F 40	DMD-F 45	DMD-F 50	DMD-F 56
	Air Volume (m ³ /h)					Air Volume (m ³ /h)				
Static Pressure (Pa)										
50						2197	3809	5636	8036	11332
75						2016	3721	5531	7923	11209
100		4411				1907	3626	5423	7807	11083
125	3197	4316	5826			1809	3524	5312	7689	10954
150	3078	4214	5716	8015	11445	1712	3414	5198	7566	10823
175	2955	4106	5602	7897	11320	1613	3295	5079	7440	10688
200	2826	3990	5484	7776	11192	1505	3168	4957	7311	10551
225	2687	3865	5360	7651	11061	1382	3032	4829	7177	10410
250	2534	3731	5232	7521	10926	1234	2886	4695	7038	10265
275	2360	3586	5097	7386	10787	1043	2730	4555	6894	10117
300	2157	3427	4957	7246	10644	785	2559	4407	6745	9965
325	1901	3254	4808	7101	10497		2372	4250	6590	9808
350	1527	3060	4652	6950	10345		2157	4083	6429	9647
375		2842	4486	6792	10188		1897	3902	6260	9482
400		2587	4308	6627	10027		1536	3705	6083	9311
425		2268	4117	6454	9860			3488	5896	9135
450			3908	6272	9687			3242	5699	8953
475			3677	6081	9508			2956	5489	8765
500			3414	5877	9323			2608	5264	8569
550			2697	5427	8930			1435	4754	8154
600				4895	8503				4122	7698
650				4215	8033				3230	7191
700				3112	7507				1158	6611
750					6902					5918
800					6174					5019
850					5198					3573
900					2700					713



DMD - F Metallic Filter Specifications

Fan Type with Metal Filter			DMD-F 35	DMD-F 40	DMD-F 45	DMD-F 50	DMD-F 56
Dimensions	W	[mm]	600	700	750	850	950
	H	[mm]	650	750	800	900	1000
	L	[mm]	1010	1180	1362	1540	1760
	S	[mm]	760	910	1070	1225	1385
	AXB	[mm]	300X140	350X140	380X150	440X170	490X200
	CXD	[mm]	540X540	640X640	690X690	790X790	890X890

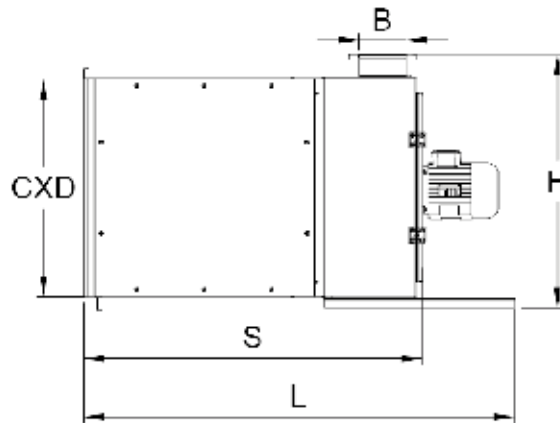
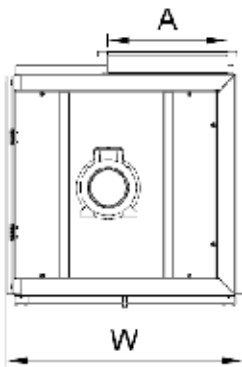

Action Carbons Filter Specifications

Active Carbon Filter			AKF-D 35	AKF-D 40	AKF-D 45	AKF-D 50	AKF-D 56
Dimensions	Length	[mm]	730	930	1030	1130	1130
	CXD	[mm]	545X545	645X645	695X695	795X795	895X895

DMK DUCT TYPE KITCHEN EXHAUST FANS

DYNFLOW DMK Duct Type Kitchen Exhaust Fans are used for kitchen smoke and gases exhausting which are generated at cooking area. DMK Duct-Type exhaust Fans are applicable to be equipped with optional metallic filter. Motor is installed out of airstream to prevent any damage due to the high airflow temperature.



Features and Benefits

- Special design with fast and easy installation and maintenance.
- Backward curved high efficiency direct driven plug fan.
- IP 55 protection class motor with F-class insulation.
- 400 Volt – 3 Phase – 50Hz.
- Motor out-of-stream arrangement.
- Options:
 - Metallic Filter with drain connection.
 - Carbon active filter.
 - Speed Controller.
 - Differential Pressure switch.

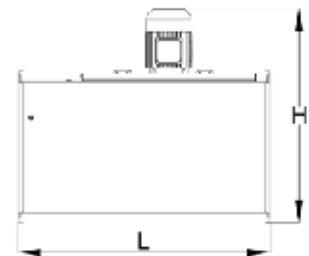
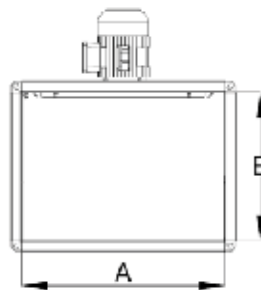

		Fan Type	DMK 35	DMK 40	DMK 45	DMK 50
Electrical Data	Connectin		400 V / 50 Hz / 3 PH			
	Power	[kW]	0.35	0.75	1.1	1.5
	RPM	[d/d]	1500	1500	1500	1500
Dimensions	A	[mm]	550	650	700	800
	B	[mm]	400	450	500	600
	L	[mm]	770	860	950	1040
	H	[mm]	655	727	797	920
	Weight	[kg]	46	61	67	96

Model	Duct Type Fan				Duct Type Fan With Filter			
	DMK 35	DMK 40	DMK 45	DMK 50	DMK-F 35	DMK-F 40	DMK-F 45	DMK-F 50
	Air Volume (m ³ /h)				Air Volume (m ³ /h)			
Static Pressure (Pa)								
50					2197	3809	5636	8036
75					2016	3721	5531	7923
100		4411			1907	3626	5423	7807
125	3101	4316	5826		1809	3524	5312	7689
150	2986	4214	5716	8015	1712	3414	5198	7566
175	2741	3990	5484	7776	1505	3168	4957	7311
200	2458	3731	5232	7521	1234	2886	4695	7038
225	2092	3427	4957	7246	785	2559	4407	6745
250	1481	3060	4652	6950		2157	4083	6429
275		2587	4308	6627		1536	3705	6083
300			3414	5877			2608	5264

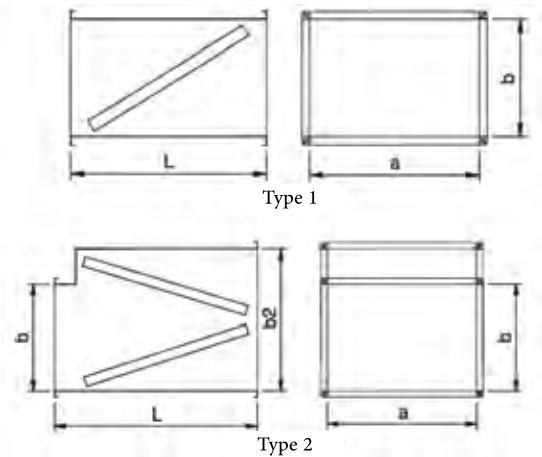

DMD - F Metallic Filter Specifications

Metal Filter					
Model		DMK-F 35	DMK-F 40	DMK-F 45	DMK-F 50
Type		Type-1		Type-2	
A	[mm]	550	650	700	800
B	[mm]	400	450	550	600
L	[mm]	600	750	950	850
b2	[mm]	---	---	670	900
Weight	[kg]	17	28	42	46

Action Carbon Filter Specifications

ACTIVE CARBON FILTER					
Model		AKF 35	AKF 40	AKF 45	AKF 50
Lenght	[mm]	940	1280	1280	1280
CXD	[mm]	400X550	450X650	500X700	600X800

DMH EC KITCHEN EXHAUST FANS

DYNFLOW DMH EC Kitchen Exhaust Fans are used for kitchen smoke and gases exhausting which are generated at cooking area. DMH EC exhaust Fans are applicable to be equipped with optional metallic filter. High efficiency EC Motor is installed out of airstream to prevent any damage due to the high airflow temperature.



DYNFLOW
ECFAN

Features and Benefits

- *Special design with fast and easy installation and maintenance.*
- *Backward curved high efficiency direct driven plug fan.*
- *Efficient operation with EC motor technology.*
- *400 Volt – 3 Phase – 50Hz.*
- *Motor out-of-stream arrangement.*
- *Options:*
 - *Metallic Filter with drain connection.*
 - *Carbon active filter.*
 - *Speed Controller.*
 - *Differential Pressure switch.*

Specifications

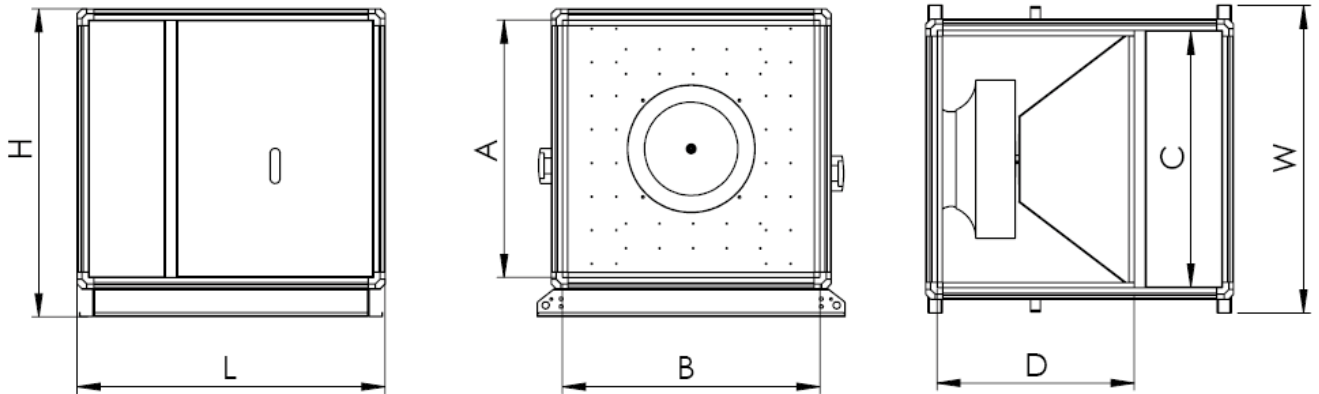

Model / Fan Type	L (mm)	W (mm)	H (mm)	AXB (mm)	CXD (mm)	(RPM)	Power (kW)	Electrical Connections
DMH 35 EC	855	800	800	620X620	620X500	1500	0.35	400 V / 50 Hz / 3PH
DMH 40 EC	955	900	900	720X720	720X600	1500	0.75	400 V / 50 Hz / 3PH
DMH 45 EC	955	1100	1100	920X920	920X600	1500	1.1	400 V / 50 Hz / 3PH
DMH 50 EC	1100	1100	1100	920X920	920X705	1500	1.5	400 V / 50 Hz / 3PH
DMH 56 EC	1120	1300	1300	1120X1120	1120X750	1500	3	400 V / 50 Hz / 3PH
DMH 63 EC	1170	1500	1500	1320X1320	1320X810	1500	5.5	400 V / 50 Hz / 3PH
DMH 71 EC	1250	1700	1700	1520X1520	1520X880	1500	7.5	400 V / 50 Hz / 3PH

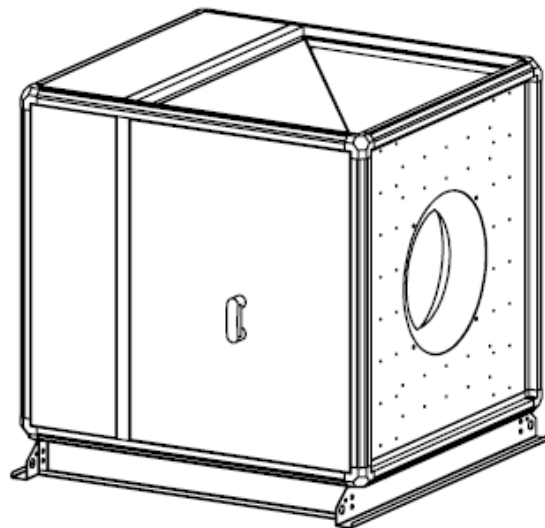

Static Pressure (Pa)	AirFlow (m ³ /h)						
	DMH EC 35	DMH EC 40	DMH EC 45	DMH EC 50	DMH EC 56	DMH EC 63	DMH EC 71
0	3668	4899	6498	8910	12508	17868	25291
50	3520	4736	6314	8709	12281	17607	25009
100	3348	4550	6113	8494	12043	17338	24717
150	3144	4343	5893	8264	11795	17060	24415
200	2898	4111	5654	8018	11535	16772	24104
250	2601	3847	5394	7754	11261	16473	23781
300	2218	3537	5109	7470	10971	16162	23448
350	1571	3155	4795	7163	10664	15837	23103
400		2662	4442	6831	10336	15498	22745
450		1860	4030	6466	9987	15142	22375
500			3520	6060	9611	14770	21991
550			2779	5597	9206	14378	21593
600				5049	8764	13964	21179
650				4345	8279	13528	20748
700				3204	7737	13064	20299
750					7114	12570	19831
800					6365	12039	19342
850					5361	11463	18829
900					3177	10830	18289
950						10122	17719
1000						9303	17115
1050						8305	16470
1100						6924	15776
1150							15021
1200							14187
1250							13244
1300							12138
1350							10745
1400							8621



DMH KITCHEN EXHAUST FANS

DYNFLOW DMH Kitchen Exhaust Fans are used for kitchen smoke and gases exhausting which are generated at cooking area. DMH Duct-Type exhaust Fans are applicable to be equipped with optional metallic filter. Motor is installed out of airstream to prevent any damage due to the high airflow temperature.

Features and Benefits

- Special design with fast and easy installation and maintenance.
- Backward curved high efficiency direct driven plug fan.
- Double skin casing with thermal insulation.
- IP 55 protection class motor with F-class insulation.
- 400 Volt – 3 Phase – 50Hz.
- Motor out-of-stream arrangement.
- Options:
 - Metallic Filter with drain connection.
 - Carbon active filter.
 - Speed Controller.
 - Differential Pressure switch.

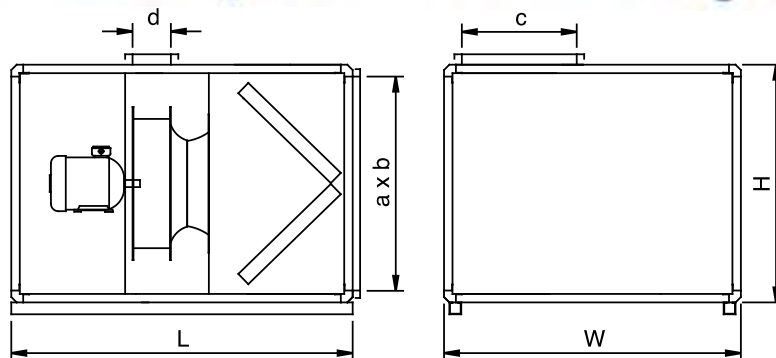

DMH Specifications

Fan Type		DMH 35	DMH 40	DMH 45	DMH 50	DMH 56	DMH 63	DMH 71	
Electrical Data	Connectin	400 V / 50 Hz / 3 PH							
	Power	[kW]	0.37	0.75	1.1	1.5	3	5.5	7.5
	Current	[A]	1.2	2.2	2.7	3.4	6.7	10.5	14.7
	RPM	[d/d]	1500	1500	1500	1500	1500	1500	1500
Dimensions	L	[mm]	985	1045	1195	1195	1645	1845	1945
	W	[mm]	600	800	800	1000	1200	1400	1600
	H	[mm]	745	945	1145	1145	1345	1500	1745
	AXB	[mm]	520X520	720X720	920X720	920X920	1120X1120	1320X1320	1520X1520
	CXD	[mm]	230X160	340X165	340X195	440X235	540X285	640X340	740X375
	Weight	[kg]	70	122	152	181	235	300	400

		Duct Type Kitchen Exhaust Fans						
		DMH 35	DMH 40	DMH 45	DMH 50	DMH 56	DMH 63	DMH 71
Static Pressure (Pa)	Model	Air Volume (m ³ /h)						
	50		1853	3545	5290	7689	11101	15213
75		1787	3448	5186	7577	10978	15097	21705
100		1715	3349	5079	7462	10852	14977	21566
125		1635	3247	4970	7344	10724	14855	21425
150		1546	3141	4857	7223	10594	14729	21282
175		1445	3030	4741	7099	10461	14600	21136
200		1330	2912	4621	6971	10324	14467	20988
225		1200	2787	4497	6840	10185	14330	20838
250		1052	2652	4368	6704	10042	14190	20686
275		884	2504	4232	6563	9895	14046	20531
300		676	2340	4090	6417	9745	13898	20373
325			2152	3940	6266	9591	13745	20212
350			1932	3779	6108	9432	13588	20049
375			1663	3606	5943	9269	13427	19883
400			1317	3418	5770	9101	13261	19714
425				3208	5588	8927	13091	19541
450				2968	5415	8747	12915	19366
475				2682	5394	8560	12735	19187
500				2317	4967	8367	12549	19005
550					4463	7954	12161	18629
600					3828	7501	11750	18238
650					2900	6993	11313	17830
700					823	6410	10849	17403
750						5709	10353	16956
800						4798	9818	16485
850						3339	9235	15989
900							8587	15463

DMC ROOF TYPE KITCHEN FANS

DYNFLOW DMC Kitchen Roof Exhaust Fans are used for kitchen smoke and gases exhausting which are generated at cooking area. Motor is installed out of airstream to prevent any damage due to the high airflow temperature.

Features and Benefits

- *Special design with fast and easy installation and maintenance.*
- *Backward curved high efficiency direct driven plug fan.*
- *IP 55 protection class motor with F-class insulation.*
- *400 Volt – 3 Phase – 50Hz.*
- *Motor out-of-stream arrangement.*
- *Options:*
 - *Speed Controller.*



Model Static Pressure (Pa)	DMC 350 V3	DMC 400 V3	DMC 450 V3	DMC 500 V3	DMC 560 V3	DMC 630 V3	DMC 710 V3	DMC 800 V3
	Air Volume (m ³ /h)							
0								
25								
50								
75								
100								
125	3088	4227						
150	2987	4126		7851	11206	16471	23195	38111
175	2875	4019	5487	7736	11083	16340	23048	37961
200	2754	3906	5371	7617	10958	16207	22899	37805
225	2620	3785	5250	7494	10830	16071	22747	37644
250	2471	3655	5124	7366	10698	15933	22592	37476
275	2304	3514	4992	7234	10562	15793	22435	37302
300	2107	3360	4854	7096	10422	15649	22276	37122
325	1859	3189	4709	6954	10279	15503	22113	36937
350	1492	2998	4555	6805	10130	15354	21948	36746
375		2780	4393	6651	9978	15201	21779	36550
400		2528	4220	6489	9820	15045	21608	36349
425		2220	4033	6320	9656	14886	21434	36143
450			3829	6142	9487	14723	21256	35934
500			3602	5955	9312	14556	21076	35721
550			3344	5757	9131	14385	20892	35505
600			2640	5317	8745	14210	20513	35065
650				4796	8326	14031	20120	34616
700				4128	7865	13659	19710	34160
750				3044	7350	13266	19284	33699
800					6759	12851	18840	33232
850					6047	12411	18375	32759
900					5093	11941	17887	32278
950					3018	11437	17375	31788
1000						10890	16833	31286
1050						10289	16259	30770
1100						9616	15647	30236
1150						8838	14987	29680
1200							14270	29098
1250							13478	28484
1300							12582	27831
1350							11531	27131
1400							10208	26375
1450							8190	25553

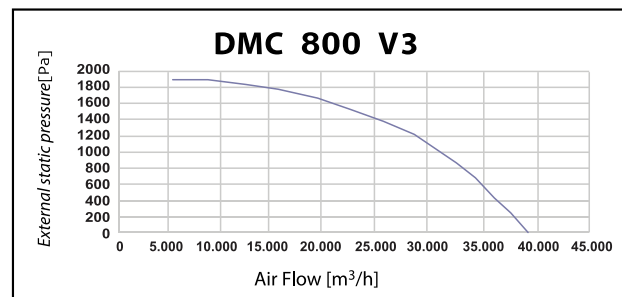
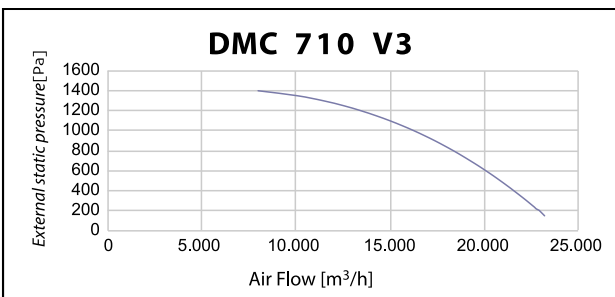
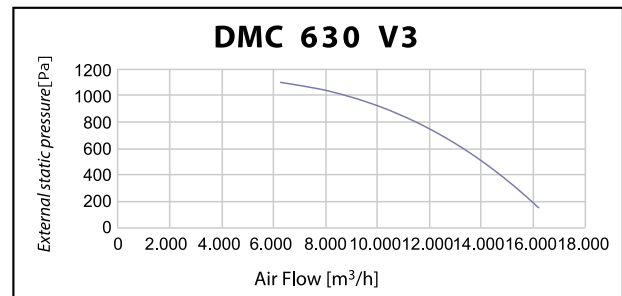
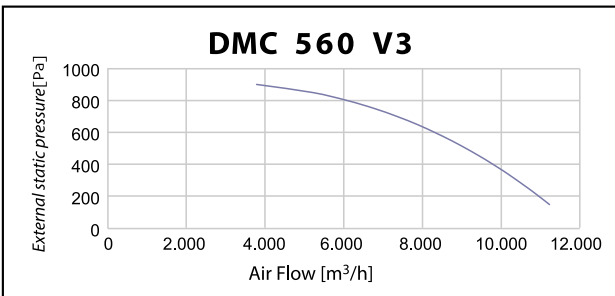
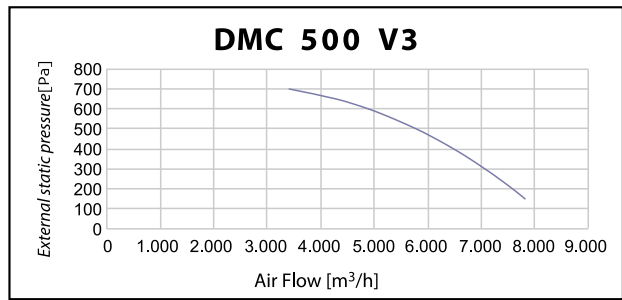
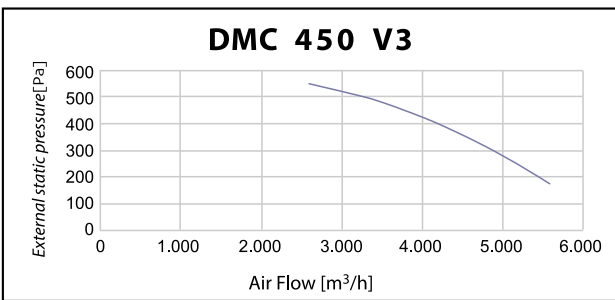
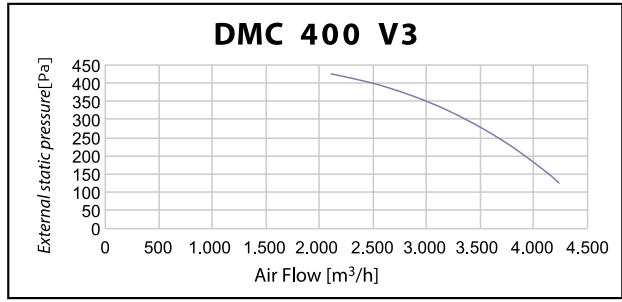
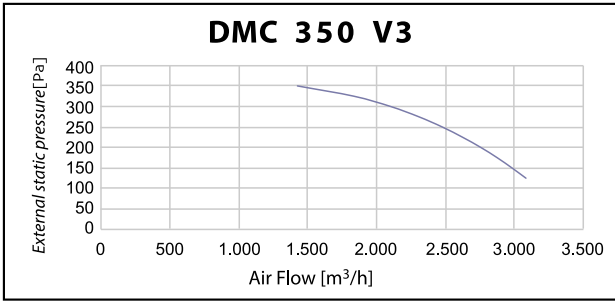

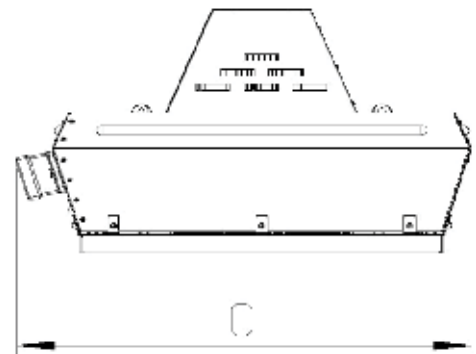
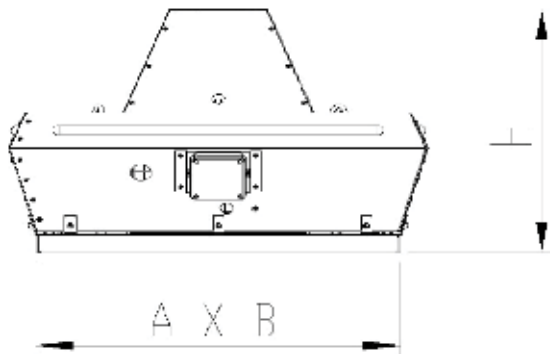

Model	DMC 350 V3	DMC 400 V3	DMC 450 V3	DMC 500 V3	DMC 560 V3	DMC 630 V3	DMC 710 V3	DMC 800 V3
Specification								
Voltage (V)	400	400	400	400	400	400	400	400
Power (kW)	0.37	0.75	1.1	1.5	3	5.5	7.5	15
Current (A)	1.2	2.2	2.7	3.4	6.7	10.5	14.7	29.9
rpm	1500	1500	1500	1500	1500	1500	1500	1500
Weight (kg)	~49	~62	~74.4	~85	~112	~140	~158	~309
A (mm)	640	705	760	810	870	904	945	1110
B (mm)	640	705	760	810	870	904	945	1110
C (mm)	800	870	930	990	1067	1165	1225	1290
H (mm)	528	582	598	650	800	910	945	1145